

Steel Reel Specifications

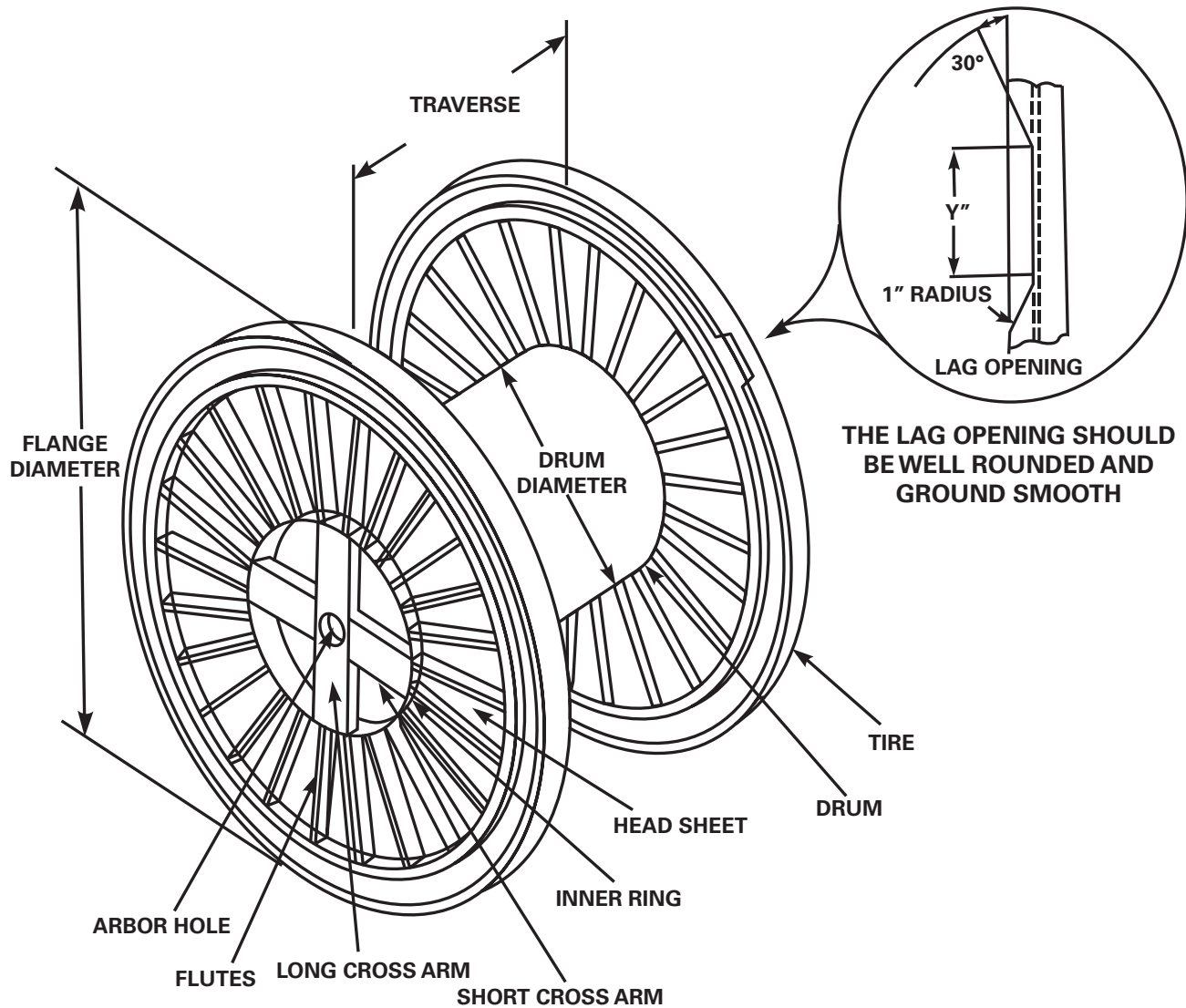

I-Beam Tire Fluted Steel Reel—Type RMT

NOTE — When required, cable test hole in the flange shall not have more than 3 flutes removed to provide this opening. The cable test hole shall be reinforced along the cutout with a metal equal to or greater than that required for use in the drum of the reel. Height of cable test hole to be no greater than one half the length.



buyawg.com | sales@buyawg.com | 800.342.7215 | 945.455.3050

Steel Reel Specifications

Type*	-Reel Dimensions-			Max. Overall Width (in)	Arbor Hole Diameter (in)	Max. Number of Flutes per Hd	Tire Size (in)	----Cross Arms----			Drum U.S.S. (ga)	Inner Ring Dimensions (in)	(Flange) Head Sheet U.S.S. (ga)	---Capacity---	
	Fl	Trav	Drum					U.S.S. (ga)	Long (in)	Short (in)				(lb)	(kg)
RM	42	24	24	33	3.25	24	2x5/16	8	5x2	4x2	12	3-3/4x3/16	16	1,956	887
RM	48	24	24	33	3.25	24	2x5/16	8	5x2	4x2	12	3-3/4x3/16	16	3,072	1,393
RM	54	32	32	41	3.25	30	2x5/16	8	5x2	4x2	12	3-3/4x3/16	16	4,464	2,024
RM	60	32	32	41	3.25	30	2x5/16	8	5x2	4x2	12	3-3/4x3/16	16	6,360	2,884
RM	66	32	36	41	3.25	32	2-1/2x1/2	8	6x2	5x2	12	3-3/4x3/16	16	7,680	3,482
RM	72	36	40	45	3.25	40	2-1/2x1/2	8	6x2	5x2	12	3-3/4x1/4	16	10,260	4,654
RM	72	36	48	45	3.25	40	2-1/2x1/2	8	6x2	5x2	12	3-3/4x1/4	16	7,872	3,570
RM	78	36	48	45	3.25	40	2-1/2x5/8†	8	6x2	5x2	12	3-3/4x1/4	16	10,752	4,876
RMT	84	36	42	45	5.25	40	7.5lb/ft, 3" I-Beam	8	7-7/8x2	6x2	10	4x1/4	16	13,608	6,171
RMT	84	45	42	55	5.25	40	7.5lb/ft, 3" I-Beam	8	7-7/8x2	6x2	10	4x1/4	16	17,004	7,711
RMT	84	45	56	55	5.25	40	7.5lb/ft, 3" I-Beam	8	7-7/8x2	6x2	10	4x1/4	16	11,196	5,050
RMT	90	45	42	55	5.25	40	7.5lb/ft, 3" I-Beam	8	7-7/8x2	6x2	10	4-1/4x1/4	16	21,036	9,540
RMT	90	45	56	55	5.25	40	7.5lb/ft, 3" I-Beam	8	7-7/8x2	6x2	10	4-1/4x1/4	16	15,216	6,900
RMT	90	54	56	64	5.25	40	7.5lb/ft, 3" I-Beam	8	7-7/8x2	6x2	8	4-1/4x1/4	16	18,252	8,277
RMT	96	60	42	71	5.25	40	7.5lb/ft, 3" I-Beam	8	7-7/8x3	6x3	8	4-1/2x5/16	14	26,000	11,719
RMT	98	60	56	71	5.25	40	7.5lb/ft, 3" I-Beam	8	7-7/8x3	6x3	8	4-1/2x5/16	14	26,000	11,719
RMT**	108	74	56	85	5.25	40	7.5lb/ft, 3" I-Beam	8	7-7/8x3	6x3	8	4-1/2x5/16	14	30,000	13,605

* RM—Flat bar tire

** Generally used for aluminum wire and cable

† Alternate size is 3x1/2 inch

RMT—I-Beam Tire

NOTE—Tie holes, if necessary, shall be in the flat portion of the head sheet. There will be no holes in the flute itself.

NOTE—A range of 3 to 3.25-inch and 5 to 5.25-inch arbor hole diameter shall be permitted for existing reels until the year 2005.

Welding Requirements for Class 1 Reels

Head sheet to tire—at all radii of flute-intermittent weld

Head sheet to inner ring—at all radii of flute-intermittent weld

Drum to inner ring—intermittent weld

Cross arm to cross arm—continuous weld

Cross arm to inner ring—continuous weld

Cross arm to hub—continuous weld

Back-up plate to hub and cross arm—continuous weld

Port frame—continuous weld

All welds shall reflect good welding practice with proper penetration.



buyawg.com | sales@buyawg.com | 800.342.7215 | 945.455.3050